

Technical Data Sheet  
Electric Motor Three phase in Aluminum IE2

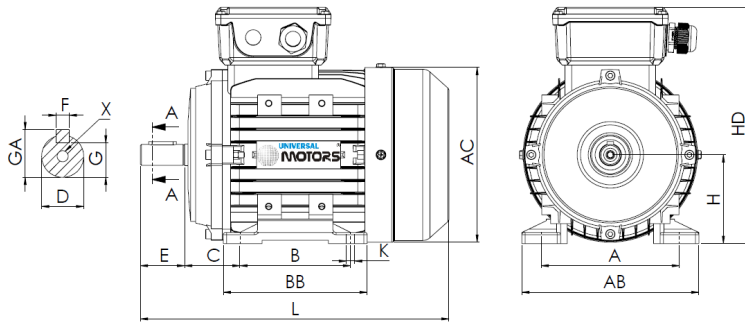

L (standard motor)

477

L (motor w/brake)

570

L (motor w/forced ventilation)

605

L (motor without ventilation)

371

Feet					Shaft						Carcass				Flange				
H	A	B	C	K	D	E	F	G	GA	X	AB	BB	AC	HD	M	N	P	S	T
132	216	178	89	12	38k6	80	10	33	41	M12x28	254	214	265	324	-	-	-	-	-

### Electrical Data

Type	HE31/UMHA* 132M1-4	
Poles	4/1500	Poles
Power	7.50	Kw
Voltage	400	V
Frequency	50	Hz
Speed	1440	rpm
Nominal current	14.70	A
Power factor	0.83	
Efficiency 100%	88.7	%
Efficiency 75%	88.9	%
Efficiency 50%	88.7	%
Torque	49.22	N.m
Ta/Tn	2	
Ia/In	7.4	
Tm/Tn	2.3	

### Mechanical Data

Shaft height	132
Construction form	B3
Mechanical protection	55
Heating class	B
Insulation class	F
Service	S3-70%
Ambient temp.	-10°C-40°C
Altitude	1000
Noise	75 dB(A)
Weight	59.5 kg
Bearing DE	6308 2Z C3
Bearing NDE	6308 2Z C3

### Extra Data

#### Applicable brakes

DC brake	REB-05-16	Brake torque	80	N.m
AC brake	AC7	Brake torque	90	N.m

#### Applicable forced ventilations

Single-phase forced ventilation	Power	55	W
Three-phase forced ventilation	Power	55	W

Universal Motors S.A.  
Rua Comendador Brandão, 484  
4495-375 Póvoa de Varzim  
[geral@universalmotors.pt](mailto:geral@universalmotors.pt)  
TEL.: 252 299 080

Universal Motors UK, Ltd  
Unit E2, Meltham Mills Road  
West Yorkshire HD9 4AR  
[enquiries@universalmotors-group.co.uk](mailto:enquiries@universalmotors-group.co.uk)  
TEL.: +44(0) 1484660222

Universal Motors SL  
C/La Habana n.6 nave 4 Pl Camporoso  
28806 Alcala de Henares  
[info@universalmotors-group.es](mailto:info@universalmotors-group.es)  
TEL.: 918 864 213