

Technical Data Sheet
 Electric Motor Three phase in Aluminum IE1

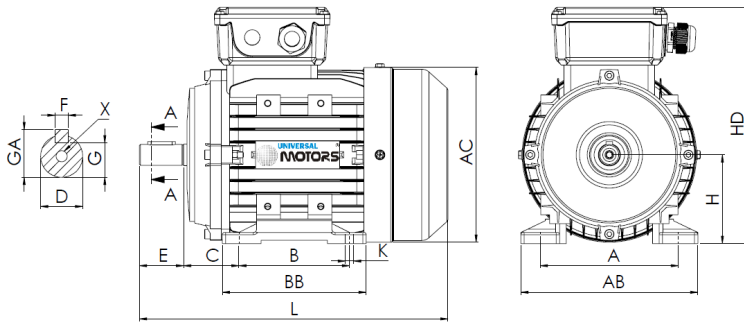

L (standard motor)

250

L (motor w/brake)

300

L (motor w/forced ventilation)

360

L (motor without ventilation)

208

Feet					Shaft						Carcass				Flange				
H	A	B	C	K	D	E	F	G	GA	X	AB	BB	AC	HD	M	N	P	S	T
71	112	90	45	7	14j6	30	5	11	16	M5x12	132	105	147	190	-	-	-	-	-

Electrical Data

Type	BF31/UMA* 71M2-4	
Poles	4/1500	Poles
Power	0.37	Kw
Voltage	400	V
Frequency	50	Hz
Speed	1400	rpm
Nominal current	1.07	A
Power factor	0.72	
Efficiency 100%	69.5	%
Efficiency 75%	-	%
Efficiency 50%	-	%
Torque	2.52	N.m
Ta/Tn	2.4	
Ia/In	6.0	
Tm/Tn	2.4	

Mechanical Data

Shaft height	71
Construction form	B3
Mechanical protection	55
Heating class	B
Insulation class	F
Service	S3-70%
Ambient temp.	-10°C-40°C
Altitude	1000
Noise	55 dB(A)
Weight	6.2 kg
Bearing DE	6202 2Z C3
Bearing NDE	6202 2Z C3

Extra Data

Applicable brakes

DC brake	REB-05-06	Brake torque	4	N.m
AC brake	AC2	Brake torque	10	N.m

Applicable forced ventilations

Single-phase forced ventilation	Power	35	W
Three-phase forced ventilation	Power	35	W

Universal Motors S.A.
 Rua Comendador Brandão, 484
 4495-375 Póvoa de Varzim
geral@universalmotors.pt
 TEL.: 252 299 080

Universal Motors UK, Ltd
 Unit E2, Meltham Mills Road
 West Yorkshire HD9 4AR
enquiries@universalmotors-group.co.uk
 TEL.: +44(0) 1484660222

Universal Motors SL
 C/La Habana n.6 nave 4 PI Camporoso
 28806 Alcala de Henares
info@universalmotors-group.es
 TEL.: 918 864 213