

Technical Data Sheet
Electric Motor Three phase in Aluminum IE3

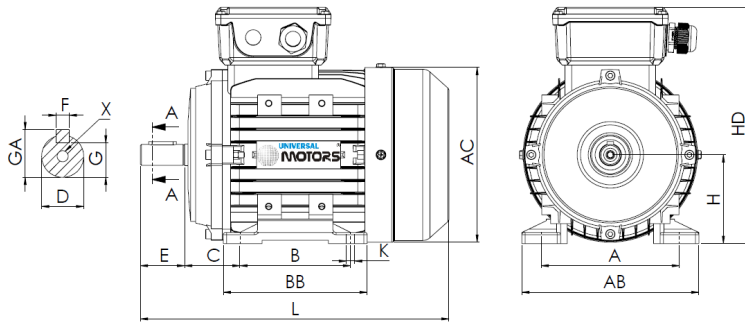

L (standard motor)

313

L (motor w/brake)

385

L (motor w/forced ventilation)

425

L (motor without ventilation)

279

Feet					Shaft						Carcass				Flange				
H	A	B	C	K	D	E	F	G	GA	X	AB	BB	AC	HD	M	N	P	S	T
90	140	125	56	10	24j6	50	8	20	27	M8x19	175	155	182	235	-	-	-	-	-

Electrical Data

Type	PE31/UM3A* 90L-4	
Poles	4/1500	Poles
Power	1.50	Kw
Voltage	400	V
Frequency	50	Hz
Speed	1435	rpm
Nominal current	3.38	A
Power factor	0.75	
Efficiency 100%	85.3	%
Efficiency 75%	84.9	%
Efficiency 50%	83.1	%
Torque	9.98	N.m
Ta/Tn	2.3	
Ia/In	6.9	
Tm/Tn	2.3	

Mechanical Data

Shaft height	90
Construction form	B3
Mechanical protection	55
Heating class	B
Insulation class	F
Service	S1
Ambient temp.	-10°C-40°C
Altitude	1000
Noise	66 dB(A)
Weight	17 kg
Bearing DE	6205 2Z C3
Bearing NDE	6204 2Z C3

Extra Data

Applicable brakes

DC brake	REB-05-10	Brake torque	16	N.m
AC brake	NA	Brake torque	NA	N.m

Applicable forced ventilations

Single-phase forced ventilation	Power	45	W
Three-phase forced ventilation	Power	45	W

Universal Motors S.A.
Rua Comendador Brandão, 484
4495-375 Póvoa de Varzim
geral@universalmotors.pt
TEL.: 252 299 080

Universal Motors UK, Ltd
Unit E2, Meltham Mills Road
West Yorkshire HD9 4AR
enquiries@universalmotors-group.co.uk
TEL.: +44(0) 1484660222

Universal Motors SL
C/La Habana n.6 nave 4 PI Camporoso
28806 Alcala de Henares
info@universalmotors-group.es
TEL.: 918 864 213