

Technical Data Sheet  
 Electric Motor Three phase in Aluminum IE2

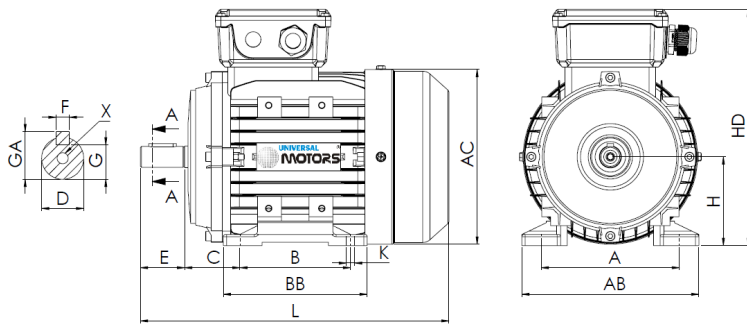

L (standard motor)

384

L (motor w/brake)

460

L (motor w/forced ventilation)

495

L (motor without ventilation)

339

Feet					Shaft						Carcass				Flange				
H	A	B	C	K	D	E	F	G	GA	X	AB	BB	AC	HD	M	N	P	S	T
100	160	140	63	12	28j6	60	8	24	31	M10x22	198	176	205	252	-	-	-	-	-

**Electrical Data**

Type	HE31/UMHA*	
	100L2-4	
Poles	4/1500	Poles
Power	3.00	Kw
Voltage	400	V
Frequency	50	Hz
Speed	1450	rpm
Nominal current	6.18	A
Power factor	0.82	
Efficiency 100%	85.5	%
Efficiency 75%	86.0	%
Efficiency 50%	85.5	%
Torque	19.76	N.m
Ta/Tn	2.3	
Ia/In	7.6	
Tm/Tn	2.3	

**Mechanical Data**

Shaft height	100	
Construction form	B3	
Mechanical protection	55	
Heating class	B	
Insulation class	F	
Service	S3-70%	
Ambient temp.	-10°C-40°C	
Altitude	1000	
Noise	70	dB(A)
Weight	29	kg
Bearing DE	6206 2Z C3	
Bearing NDE	6206 2Z C3	

**Extra Data**

**Applicable brakes**

DC brake	REB-05-12	Brake torque	32	N.m
AC brake	AC5	Brake torque	40	N.m

**Applicable forced ventilations**

Single-phase forced ventilation	Power	65	W
Three-phase forced ventilation	Power	65	W

Universal Motors S.A.  
 Rua Comendador Brandão, 484  
 4495-375 Póvoa de Varzim  
[geral@universalmotors.pt](mailto:geral@universalmotors.pt)  
 TEL.: 252 299 080

Universal Motors UK, Ltd  
 Unit E2, Meltham Mills Road  
 West Yorkshire HD9 4AR  
[enquiries@universalmotors-group.co.uk](mailto:enquiries@universalmotors-group.co.uk)  
 TEL.: +44(0) 1484660222

Universal Motors SL  
 C/La Habana n.6 nave 4 Pl Camporosso  
 28806 Alcala de Henares  
[info@universalmotors-group.es](mailto:info@universalmotors-group.es)  
 TEL.: 918 864 213