

Technical Data Sheet  
 Electric Motor Three phase in Aluminum IE2

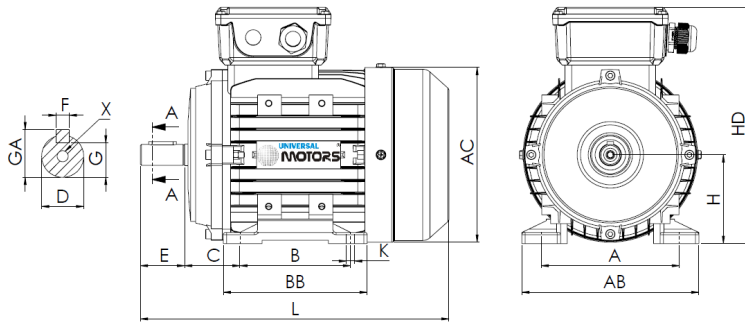

L (standard motor)

636

L (motor w/brake)

NA

L (motor w/forced ventilation)

755

L (motor without ventilation)

577

Feet					Shaft						Carcass				Flange				
H	A	B	C	K	D	E	F	G	GA	X	AB	BB	AC	HD	M	N	P	S	T
160	254	254	108	15	42k6	110	12	37	45	M16x36	290	294	326	390	-	-	-	-	-

**Electrical Data**

Type	HE31/UMHA*	
	160L2-2	
Poles	2/3000	Poles
Power	22.00	Kw
Voltage	400	V
Frequency	50	Hz
Speed	2890	rpm
Nominal current	38.64	A
Power factor	0.90	
Efficiency 100%	91.3	%
Efficiency 75%	91.7	%
Efficiency 50%	91.0	%
Torque	72.69	N.m
Ta/Tn	4.1	
Ia/In	10.0	
Tm/Tn	3	

**Mechanical Data**

Shaft height	160
Construction form	B3
Mechanical protection	55
Heating class	B
Insulation class	F
Service	S3-70%
Ambient temp.	-10°C-40°C
Altitude	1000
Noise	85 dB(A)
Weight	127 kg
Bearing DE	6309 2Z C3
Bearing NDE	6209 2Z C3

**Extra Data**

**Applicable brakes**

DC brake	NA	Brake torque	NA	N.m
AC brake	NA	Brake torque	NA	N.m

**Applicable forced ventilations**

Single-phase forced ventilation	Power	NA	W
Three-phase forced ventilation	Power	60	W

Universal Motors S.A.  
 Rua Comendador Brandão, 484  
 4495-375 Póvoa de Varzim  
[geral@universalmotors.pt](mailto:geral@universalmotors.pt)  
 TEL.: 252 299 080

Universal Motors UK, Ltd  
 Unit E2, Meltham Mills Road  
 West Yorkshire HD9 4AR  
[enquiries@universalmotors-group.co.uk](mailto:enquiries@universalmotors-group.co.uk)  
 TEL.: +44(0) 1484660222

Universal Motors SL  
 C/La Habana n.6 nave 4 Pl Camporosso  
 28806 Alcala de Henares  
[info@universalmotors-group.es](mailto:info@universalmotors-group.es)  
 TEL.: 918 864 213