

Technical Data Sheet  
 Electric Motor 1 phase in Aluminum IE2

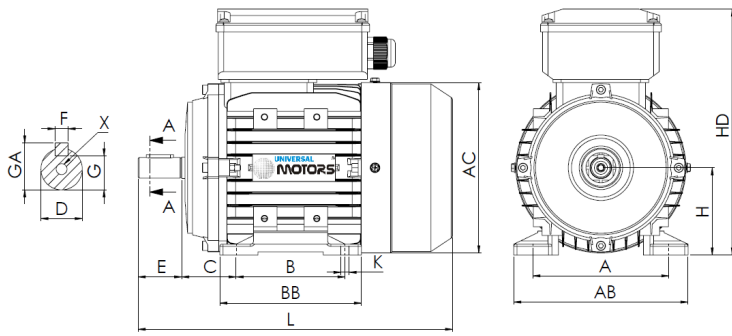

L (standard motor)

312

L (motor w/brake)

371

L (motor w/forced ventilation)

417

L (motor without ventilation)

266

Feet					Shaft						Carcass				Flange				
H	A	B	C	K	D	E	F	G	GA	X	AB	BB	AC	HD	M	N	P	S	T
90	140	100	56	10	24j6	50	8	20	27	M8x19	175	130	175	243	-	-	-	-	-

**Electrical Data**

Type	UMM2C 90S-2	
Poles	2/3000	Poles
Power	1.50	Kw
Voltage	230	V
Frequency	50	Hz
Speed	2875	rpm
Nominal current	8.10	A
Power factor	0.99	
Efficiency 100%	81.3	%
Efficiency 75%	79.4	%
Efficiency 50%	73.1	%
Torque	4.98	N.m
Ta/Tn	0.35	
Ia/In	5.4	
Tm/Tn	1.8	

**Mechanical Data**

Shaft height	90
Construction form	B3
Mechanical protection	55
Heating class	B
Insulation class	F
Service	S1
Ambient temp.	-10°C-40°C
Altitude	1000
Noise	- dB(A)
Weight	14.61 kg
Bearing DE	6205 2Z C3
Bearing NDE	6205 2Z C3

**Extra Data**

**Applicable brakes**

DC brake	REB-05-10	Brake torque	16	N.m
AC brake	NA	Brake torque	NA	N.m

**Applicable forced ventilations**

Single-phase forced ventilation	Power	45	W
Three-phase forced ventilation	Power	NA	W

Universal Motors S.A.  
 Rua Comendador Brandão, 484  
 4495-375 Póvoa de Varzim  
[geral@universalmotors.pt](mailto:geral@universalmotors.pt)  
 TEL.: 252 299 080

Universal Motors UK, Ltd  
 Unit E2, Meltham Mills Road  
 West Yorkshire HD9 4AR  
[enquiries@universalmotors-group.co.uk](mailto:enquiries@universalmotors-group.co.uk)  
 TEL.: +44(0) 1484660222

Universal Motors SL  
 C/La Habana n.6 nave 4 PI Camporoso  
 28806 Alcala de Henares  
[info@universalmotors-group.es](mailto:info@universalmotors-group.es)  
 TEL.: 918 864 213