

Technical Data Sheet  
 Electric Motor Three phase in Aluminum IE2

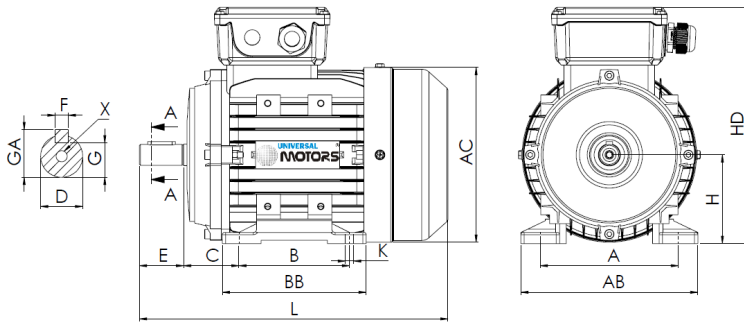

L (standard motor)

390

L (motor w/brake)

490

L (motor w/forced ventilation)

505

L (motor without ventilation)

340

Feet					Shaft						Carcass				Flange				
H	A	B	C	K	D	E	F	G	GA	X	AB	BB	AC	HD	M	N	P	S	T
112	190	140	70	12	28j6	60	8	24	31	M10x22	220	180	230	286	-	-	-	-	-

**Electrical Data**

Type	HE31/UMHA* 112M1-4	
Poles	4/1500	Poles
Power	4.00	Kw
Voltage	400	V
Frequency	50	Hz
Speed	1450	rpm
Nominal current	8.13	A
Power factor	0.82	
Efficiency 100%	86.6	%
Efficiency 75%	86.8	%
Efficiency 50%	85.9	%
Torque	26.34	N.m
Ta/Tn	2.3	
Ia/In	7.7	
Tm/Tn	2.3	

**Mechanical Data**

Shaft height	112	
Construction form	B3	
Mechanical protection	55	
Heating class	B	
Insulation class	F	
Service	S3-70%	
Ambient temp.	-10°C-40°C	
Altitude	1000	
Noise	72	dB(A)
Weight	39	kg
Bearing DE	6306 2Z C3	
Bearing NDE	6306 2Z C3	

**Extra Data**

**Applicable brakes**

DC brake	REB-05-14	Brake torque	60	N.m
AC brake	AC6	Brake torque	60	N.m

**Applicable forced ventilations**

Single-phase forced ventilation	Power	80	W
Three-phase forced ventilation	Power	80	W

Universal Motors S.A.  
 Rua Comendador Brandão, 484  
 4495-375 Póvoa de Varzim  
[geral@universalmotors.pt](mailto:geral@universalmotors.pt)  
 TEL.: 252 299 080

Universal Motors UK, Ltd  
 Unit E2, Meltham Mills Road  
 West Yorkshire HD9 4AR  
[enquiries@universalmotors-group.co.uk](mailto:enquiries@universalmotors-group.co.uk)  
 TEL.: +44(0) 1484660222

Universal Motors SL  
 C/La Habana n.6 nave 4 Pl Camporosso  
 28806 Alcala de Henares  
[info@universalmotors-group.es](mailto:info@universalmotors-group.es)  
 TEL.: 918 864 213