

Technical Data

Power 4.0kW

SUPPLY	AC 3PH 380-440V
INPUT CURRENT G*	13.5 A
INPUT CURRENT P	A
OUTPUT VOLTAGE	3PH 0~Vin V
OUTPUT CURRENT G	9.5 A
OUTPUT CURRENT P	A
IP	20
EMC FILTER C3	built-in
EMC FILTER C2	optional
BRAKING UNIT	built-in



*G represents the constant torque and P represents the variable torque

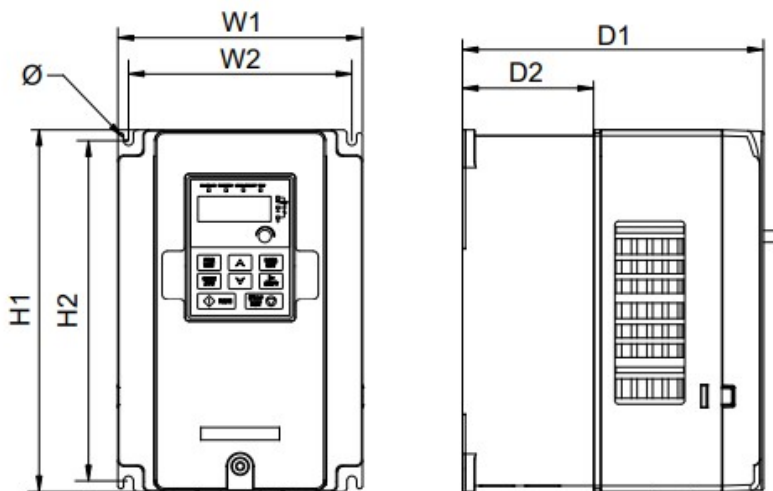

Installation dimensions

H1	256 mm
H2	243.5 mm
H3	- mm
W1	146 mm
W2	131 mm
W3	- mm
W4	- mm
D1	167 mm
D2	84.5 mm
Hole diameter	6 mm
Screw	M5

Control Diagram

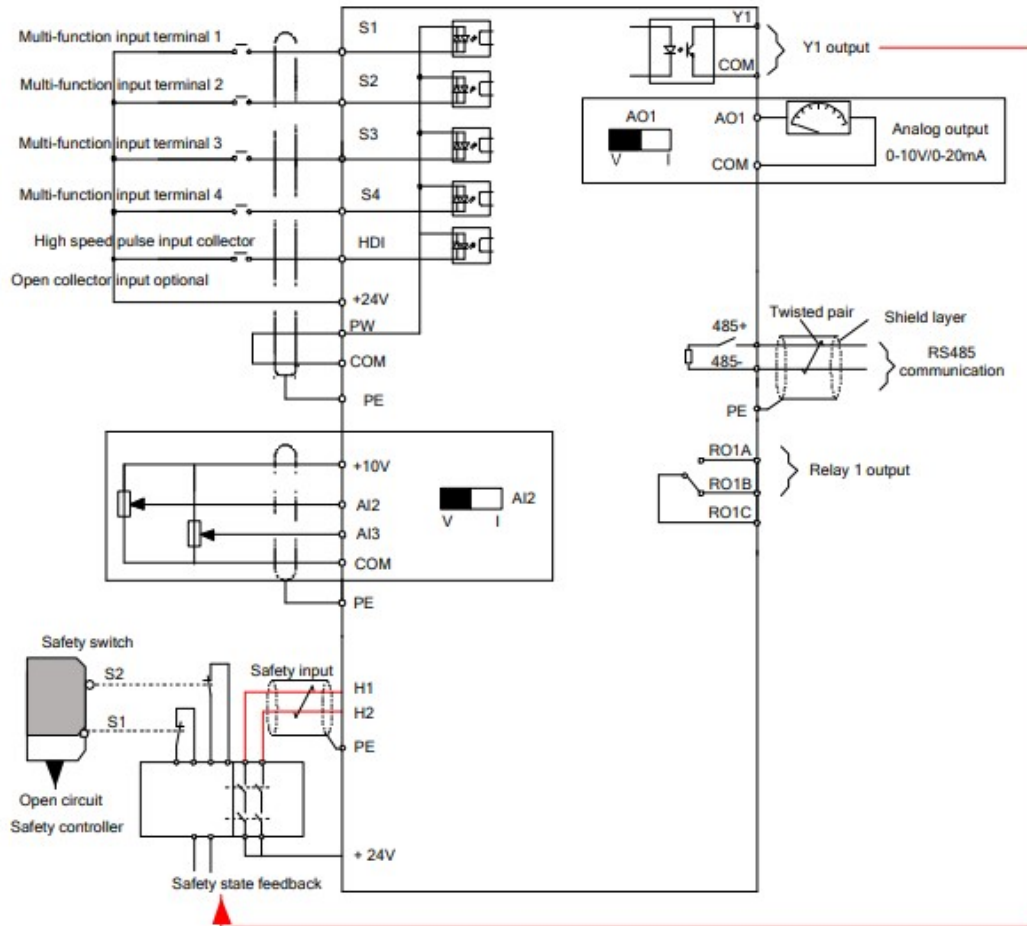

Packaging size

Height	343	mm
Width	230	mm
Depth	270	mm
Weight	3.9	Kg