

Technical Data

Power 2.2kW

SUPPLY	AC 3PH 380-440V
INPUT CURRENT G*	5.8 A
INPUT CURRENT P	A
OUTPUT VOLTAGE	3PH 0~Vin V
OUTPUT CURRENT G	5 A
OUTPUT CURRENT P	A
IP	20
EMC FILTER C3	built-in
EMC FILTER C2	optional
BRAKING UNIT	built-in



*G represents the constant torque and P represents the variable torque

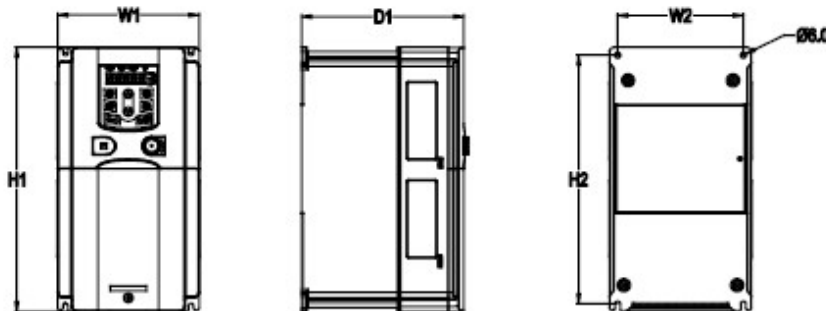

Installation dimensions

H1	186 mm
H2	175 mm
H3	- mm
W1	126 mm
W2	115 mm
W3	- mm
W4	- mm
D1	174.5 mm
D2	- mm
Hole diameter	5 mm
Screw	M4

Control Diagram

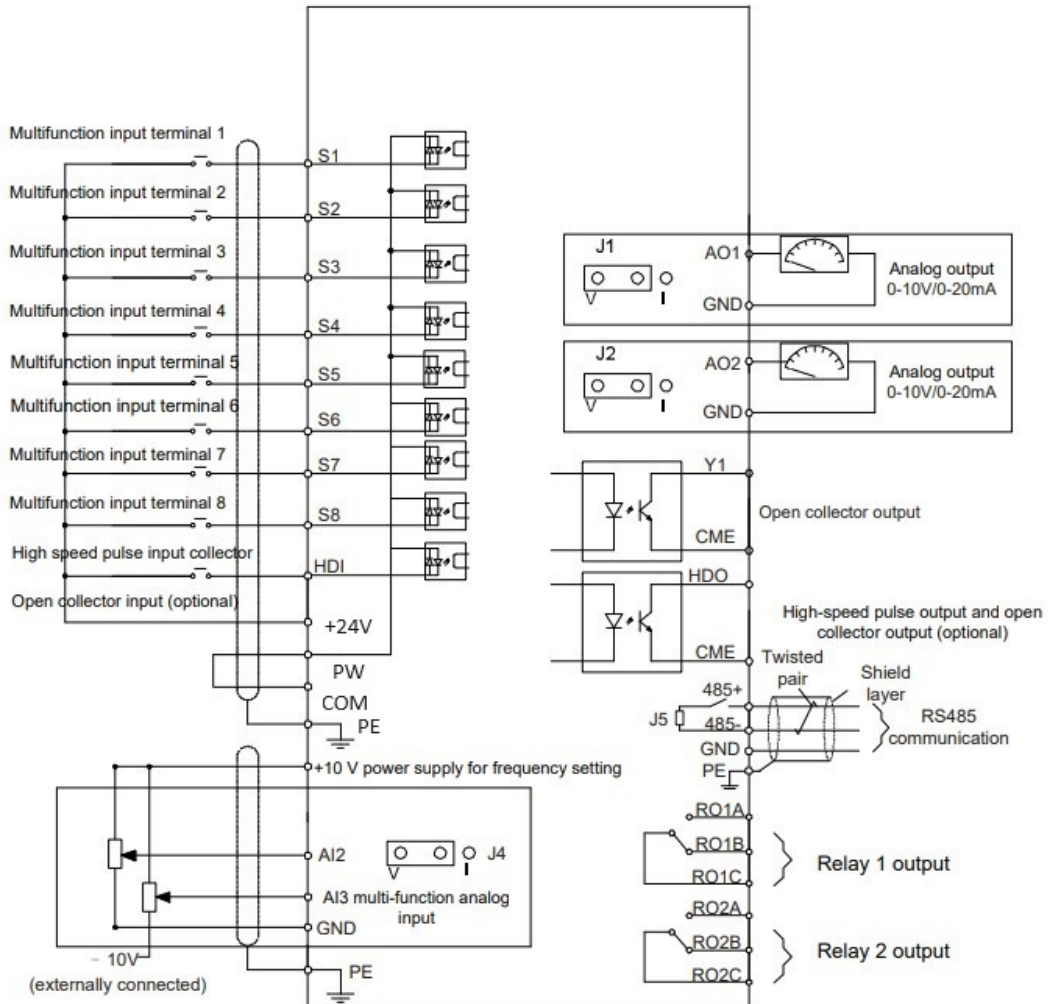

Packaging size

Height	275	mm
Width	205	mm
Depth	235	mm
Weight	2.5	Kg