

Technical Data

Power 315kW

| | |
|------------------|-----------------|
| SUPPLY | AC 3PH 380-440V |
| INPUT CURRENT G* | 610 A |
| INPUT CURRENT P | 625 A |
| OUTPUT VOLTAGE | 3PH 0~Vin V |
| OUTPUT CURRENT G | 600 A |
| OUTPUT CURRENT P | 650 A |
| IP | 20 |
| EMC FILTER C3 | built-in |
| EMC FILTER C2 | optional |
| BRAKING UNIT | optional |



*G represents the constant torque and P represents the variable torque

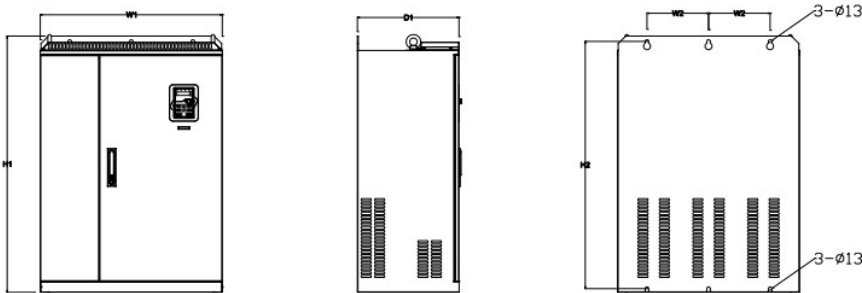

Installation dimensions

| | |
|---------------|----------|
| H1 | 960 mm |
| H2 | 926 mm |
| H3 | - mm |
| W1 | 680 mm |
| W2 | 230 mm |
| W3 | - mm |
| W4 | - mm |
| D1 | 387.9 mm |
| D2 | - mm |
| Hole diameter | 12\13 mm |
| Screw | M10/M12 |

Control Diagram

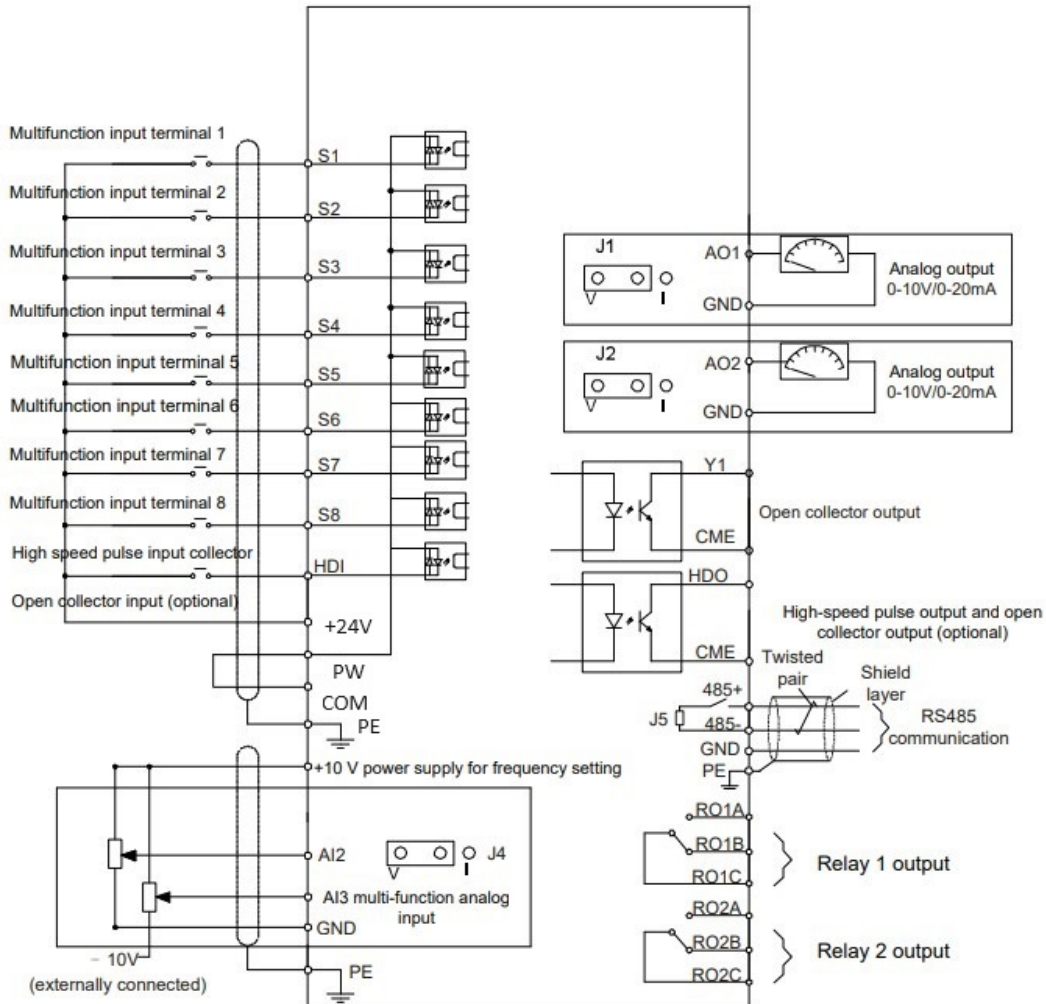

Packaging size

| | | |
|--------|------|----|
| Height | 1086 | mm |
| Width | 826 | mm |
| Depth | 595 | mm |
| Weight | 165 | Kg |