

Technical Data

Power 30kW

SUPPLY	AC 3PH 380-440V
INPUT CURRENT G*	64 A
INPUT CURRENT P	80 A
OUTPUT VOLTAGE	3PH 0~Vin V
OUTPUT CURRENT G	60 A
OUTPUT CURRENT P	75 A
IP	20
EMC FILTER C3	built-in
EMC FILTER C2	optional
BRAKING UNIT	built-in



*G represents the constant torque and P represents the variable torque

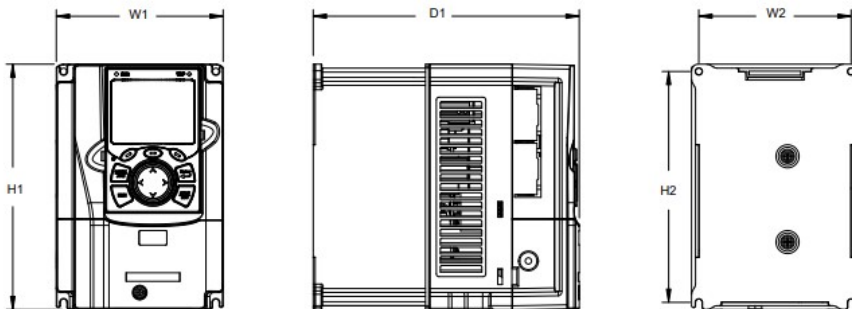

Installation dimensions

H1	400 mm
H2	380 mm
H3	- mm
W1	250 mm
W2	230 mm
W3	- mm
W4	- mm
D1	223 mm
D2	- mm
Hole diameter	6 mm
Screw	M5

Control Diagram

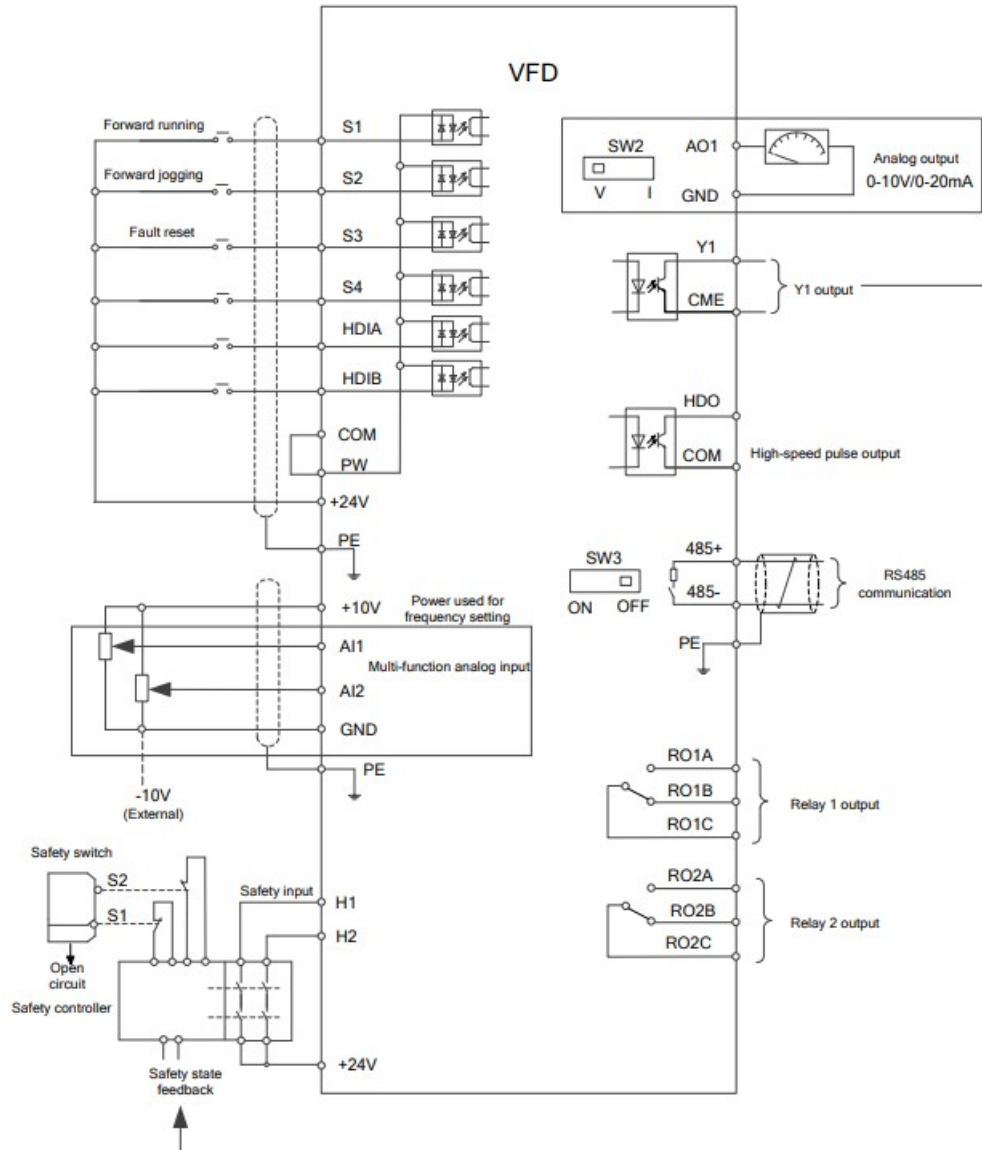

Packaging size

Height	580	mm
Width	395	mm
Depth	360	mm
Weight	17	Kg