

| | | |
|--------------------|--------|-----|
| MODEL | 512A | |
| Ø OUTPUT SHAFT | 30 | mm |
| APPROXIMATE RATIO | 24.5 | |
| EXACT RATIO | 24.61 | |
| OUTPUT SPEED | 60 | RPM |
| EXACT OUTPUT SPEED | 59 | RPM |
| INPUT POWER | 2.20 | KW |
| INPUT ROTATION | 1400 | RPM |
| INPUT PAM | 100B5 | |
| OUTPUT TORQUE | 354.53 | N.m |
| NOMINAL TORQUE | 326.00 | N.m |
| NOMINAL POWER | 2 | KW |
| SERVICE FACTOR | 0.91 | |
| DYNAMIC EFFICIENCY | 0.96 | |

Oil Quantity (L)

| B3/H1 | B6/H4 | B7/H3 | B8/H2 | V5/H5 | V6/H6 |
|-------|-------|-------|-------|-------|-------|
| 0.7 | 0.8 | 1.15 | 1.2 | 1.15 | 1.25 |

Radial and Axial Loads



| n_2 [min-1] | F_A [N] | F_R [N] |
|---------------|-----------|-----------|
| 300 | 460 | 2300 |
| 200 | 520 | 2600 |
| 120 | 620 | 3100 |
| 15 | 1000 | 5000 |

Universal Motors S.A.
Rua Comendador Brandão, 484
4495-375 Póvoa de Varzim
geral@universalmotors.pt
TEL.: 252 299 080

Universal Motors UK, Ltd
Unit E2, Meltham Mills Road
West Yorkshire HD9 4AR
enquiries@universalmotors-group.co.uk
TEL.: +44(0) 1484660222

Universal Motors SL
C/La Habana n.6 nave 4 PI Camporoso
28806 Alcala de Henares
info@universalmotors-group.es
TEL.: 918 864 213

P512A **B1** ... With feet
Con piedini

Gearbox weight **11.7 kg**
peso riduttore With feet **11.9 Kg**



Feet / piedini

| Feet Code | Market reference | G | H | R | L | S | H1 | O | øl | S2 only with motor flange | B5 max. Flange | kit code |
|-----------|------------------|----|-----|---------|-------|-----|-----|----|----|---------------------------|----------------|------------|
| B3 | 312/3 | 18 | 110 | 160 | 130 | 190 | 211 | 20 | 11 | 10 100/112B5 35 132B5 | - | KC50.9.024 |
| B4 | 30/35 | 20 | 130 | 180 | 149.5 | 216 | 231 | 18 | 14 | 15 132B5 | - | KC60.9.024 |
| S4 | 47-57 | 30 | 115 | 135 | 165 | 170 | 216 | 25 | 14 | 5 100/112B5 30 132B5 | - | KC50.9.022 |
| H3 | 023-233 | 30 | 130 | 135 | 135 | 185 | 231 | 25 | 14 | 15 132B5 | - | KC50.9.025 |
| M2 | 52/3 | 30 | 110 | 135-150 | 100 | 190 | 211 | 18 | 11 | 10 100/112B5 35 132B5 | - | KC50.9.023 |

Other feet are available, see our web site
Sono disponibili altri piedini, consulta il nostro sito web

A see on page bottom

Most popular types
Tipi più diffusi

P512A-**F** ... Output flanges
flange di uscita

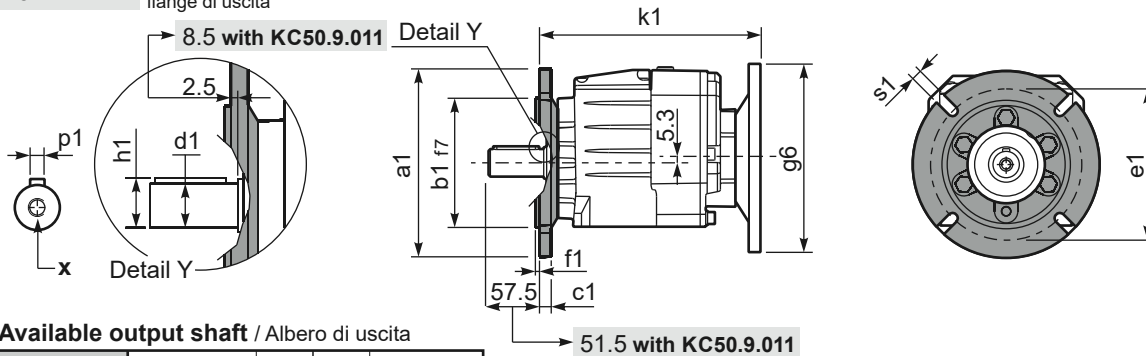

*Available output shaft / Alberi di uscita

| | Shaft - d1 | p1 | h1 | x |
|---------------------------|------------|----|----|--------|
| Standard | ø 30x60 | 8 | 33 | M10x22 |
| On request A richiesta | ø 24x50 | 8 | 27 | M8x19 |
| | ø 25x50 | 8 | 28 | M8x19 |
| | ø 28x60 | 8 | 31 | M8x19 |
| | ø 35x60 | 10 | 38 | M10x22 |

Available output flanges / flange di uscita

| a1 ø | b1 | c1 | e1 | f1 | s1 | kit code |
|------|-----|------|-----|-----|----|------------|
| 160 | 110 | 14 | 130 | 3.5 | 11 | KC50.9.011 |
| 200 | 130 | 13 | 165 | 3.5 | 11 | KC50.9.012 |
| 250 | 180 | 15.5 | 215 | 4 | 14 | KC50.9.013 |

With flange and feet only on request.
Ask for compatibility

P512A-**N** ... Basic gearbox
Riduttore base

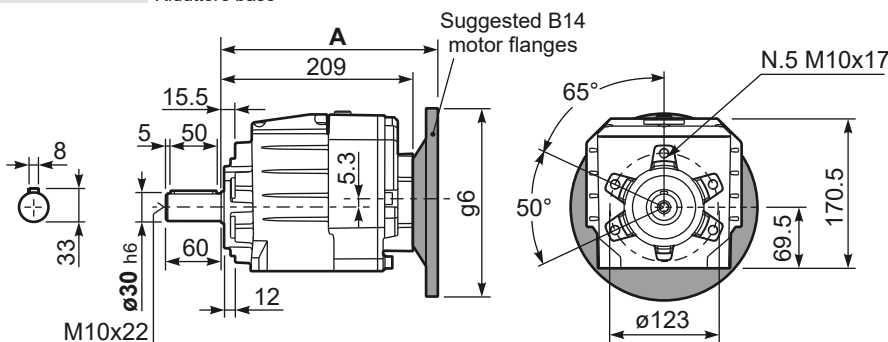

R512A-N ... Input Shaft
Albero in entrata

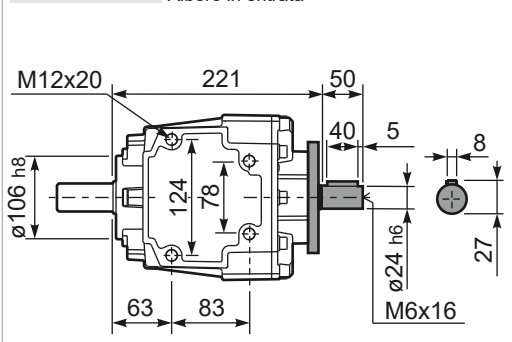

| B5 Motor Flanges | A | C _{max} | g6 | k1 | kit code | k1 with KC50.9.011 | B14 Motor Flanges | A | C _{max} | g6 | k1 | kit code | k1 with KC50.9.011 |
|------------------|-------|------------------|-----|-----|------------|--------------------|-------------------|-------|------------------|-----|-----|------------|--------------------|
| 71 B5 | 227.5 | 215.3 | 160 | 230 | K023.4.041 | 236 | 80 B14 | 229.5 | 195.3 | 120 | 232 | K085.4.046 | 238 |
| 80/90 B5 | 229.5 | 235.3 | 200 | 232 | K023.4.042 | 238 | 90 B14 | 229.5 | 205.3 | 140 | 232 | K085.4.045 | 238 |
| 100/112 B5 | 238.5 | 260.3 | 250 | 241 | K023.4.043 | 247 | 100/112 B14 | 238.5 | 215.3 | 160 | 241 | K085.4.047 | 247 |
| 132 B5 | 259.5 | 285.3 | 300 | 259 | KC51.4.043 | 265 | 132 B14 | 259.5 | 235.3 | 200 | 259 | KC51.4.041 | 265 |