

MODELO	UMSG63	
Ø EJE DE SALIDA	25	mm
RELACIÓN APROXIMADA	25	
RELACIÓN EXACTA	25.00	
VELOCIDAD DE SALIDA	58	RPM
VELOCIDAD DE SALIDA EXACTA	58	RPM
POTENCIA DE ENTRADA	0.75	KW
ROTACIÓN DE ENTRADA	1400	RPM
PAM DE ENTRADA	80B5	
PAR DE SALIDA	99.76	N.m
PAR NOMINAL	133.01	N.m
POTENCIA NOMINAL	1	KW
FACTOR DE SERVICIO	1.33	
EFICIENCIA DINÁMICA	0.78	



Cantidad de Aceite (L)

B3/H1	B6/H4	B7/H3	B8/H2	V5/H5	V6/H6
0.3	0.3	0.3	0.3	0.3	0.3

Cargas Radiales y Axiales



n_2 [min ⁻¹]	FA [N]	FR [N]
200	360	1800
100	460	2300
50	600	3000
15	800	4000

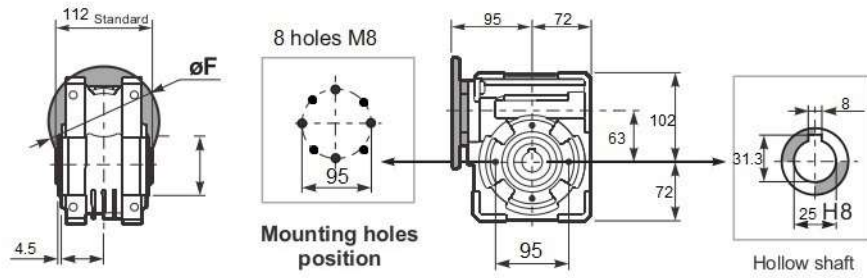

Square flange FA

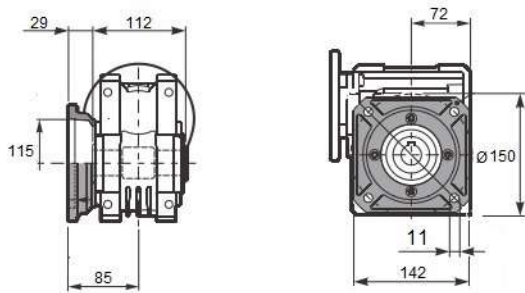

Square flange FB

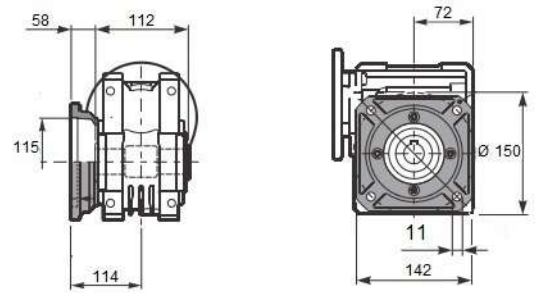

Feet

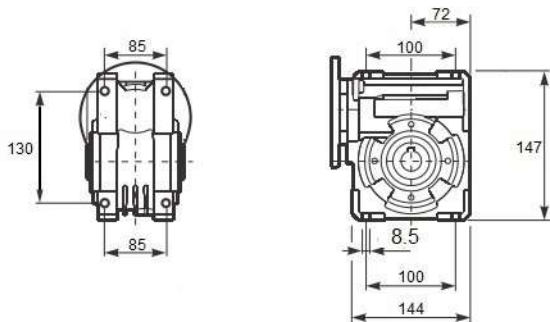

Reaction arm

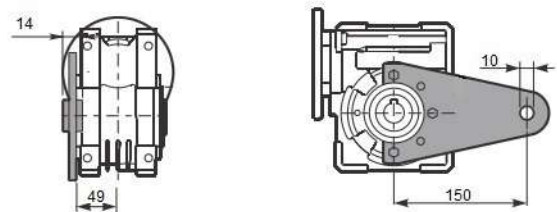

Single Shaft

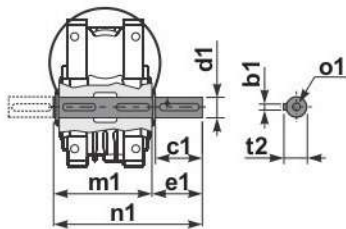

b1	c1	d1	e1	m1	n1	t2	o1
8	50	25	53.5	112	173	28	M10

1400 rpm	N2	Relação	P1	FS	P1n	M2	Rend.	Fr max	Veio		Flanges de entrada		
	rpm	i	kW		kW	Nm	%	N	Entrada	Saída	71	80	90
UMSG63	187	7,5	2,2	1,3	2,8	126	0,88	2359	24	25		B14/B5	B14/B5
	140	10	2,2	1,0	2,2	129	0,87	2597				B14/B5	B14/B5
	93	15	1,5	1,1	1,65	134	0,83	2973				B14/B5	B14/B5
	70	20	1,1	1,1	1,2	131	0,81	3272				B14/B5	B14/B5
	56	25	1,1	0,9	1	131	0,78	3524				B14/B5	B14/B5
	47	30	1,1	1,0	1,1	164	0,74	3745				B14/B5	B14/B5
	35	40	0,75	1,0	0,76	143	0,7	4122	19	25	B14/B5	B14/B5	B14/B5
	28	50	0,55	1,1	0,6	133	0,66	4440				B14/B5	B14/B5
	23	60	0,55	0,9	0,51	130	0,62	4719				B14/B5	B14/B5
	18	80	0,37	1,1	0,39	119	0,57	5193				B14/B5	B14/B5
	14	100	0,37	0,9	0,34	118	0,51	5592	14		B14/B5		