

MODELO	UMSG150	
Ø EJE DE SALIDA	50	mm
RELACIÓN APROXIMADA	100	
RELACIÓN EXACTA	100.00	
VELOCIDAD DE SALIDA	15	RPM
VELOCIDAD DE SALIDA EXACTA	15	RPM
POTENCIA DE ENTRADA	2.20	KW
ROTACIÓN DE ENTRADA	1400	RPM
PAM DE ENTRADA	100B5	
PAR DE SALIDA	960.39	N.m
PAR NOMINAL	960.39	N.m
POTENCIA NOMINAL	2.2	KW
FACTOR DE SERVICIO	1.00	
EFICIENCIA DINÁMICA	0.64	



Cantidad de Aceite (L)

B3/H1	B6/H4	B7/H3	B8/H2	V5/H5	V6/H6
7	5.1	5.1	5.4	7	5.1

Cargas Radiales y Axiales



n_2 [min ⁻¹]	FA [N]	FR [N]
200	1300	6500
100	1640	8200
50	2120	10600
15	3300	16500

Basic wormbox



Square flange FA



Single Shaft

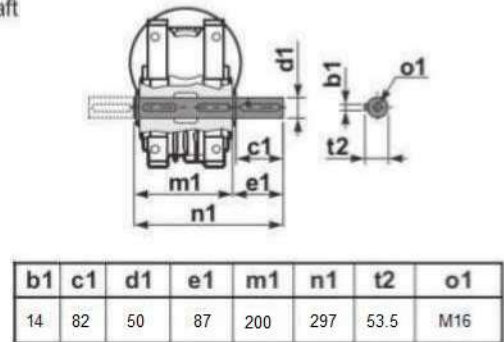

Feet

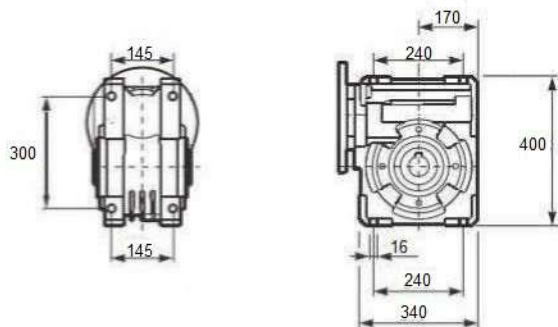

Reaction arm

