

MODELO	X335	
Ø VEIO SAÍDA	20	mm
RÁCIO APROXIMADO	92	
RÁCIO EXATO	92.31	
VELOCIDADE SAÍDA	16	RPM
VELOCIDADE SAÍDA EXATA	16	RPM
POTÊNCIA ENTRADA	0.12	KW
ROTAÇÃO ENTRADA	1400	RPM
PAM ENTRADA	63B5	
TORQUE SAÍDA	71.02	N.m
TORQUE NOMINAL	100.00	N.m
POTÊNCIA NOMINAL	0.17	KW
FATOR SERVIÇO	1.42	
EFICIÊNCIA DINÂMICA	0.94	

QUANTIDADE DE ÓLEO (L)

B3/H1	B6/H4	B7/H3	B8/H2	V5/H5	V6/H6
0.7	0.65	0.4	0.65	0.95	0.65

CARGAS RADIAIS E AXIAIS



$n_2$ [min-1]	$F_A$ [N]	$F_R$ [N]
250	400	2000
100	500	2500
50	560	2800
15	560	2800

**PX33SC...** Basic Gearbox  
Riduttore base

Gearbox weight  
peso riduttore **6.55 kg**

M. flanges	Kit code	øF	A
<b>63B5</b>	K050.4.041	138	189.5
<b>71B5</b>	K050.4.042	160	187
<b>56B14</b>	KC40.4.049	80	187
<b>63B14</b>	K050.4.047	90	189.5
<b>71B14</b>	K050.4.045	105	187



**PX33S...FB..** Feet  
Piedini



**PX33S...-F1..** Output flange  
Flangia uscita

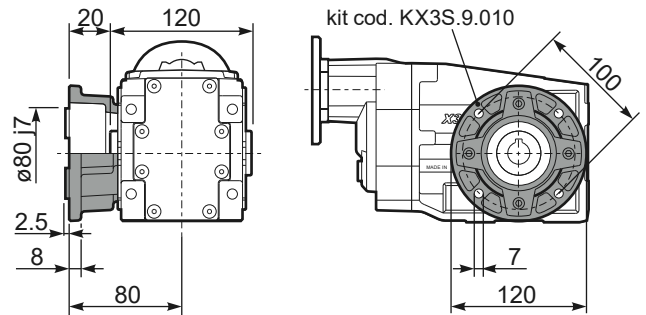

**PX33S...-F2..** Output flange  
Flangia uscita



**PX33S...BR..** Reaction Arm  
Braccio di reazione



**RX33S...** Input shaft  
Albero in entrata

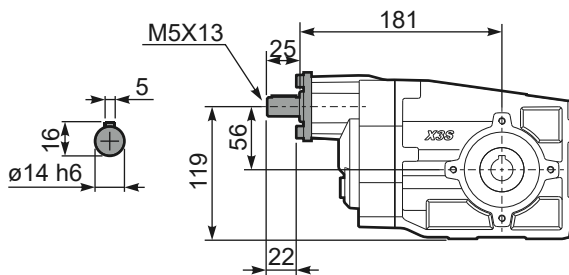

**PX33SA..** Single output shaft  
Albero semplice in uscita



d1	b1	c1	e1	m1	n1	t2	o1	1 kit code
ø20 k6	6	37.5	40	120	160	22.5	M8x20	KX2S.5.028
ø25 <sup>-0.005</sup> <sub>-0.020</sub>	8	60	63.2	126.8	190	28	M8x20	K063.5.028