

MODELO	UMSG50	
Ø VEIO SAÍDA	25	mm
RÁCIO APROXIMADO	15	
RÁCIO EXATO	15.00	
VELOCIDADE SAÍDA	97	RPM
VELOCIDADE SAÍDA EXATA	97	RPM
POTÊNCIA ENTRADA	0.37	KW
ROTAÇÃO ENTRADA	1400	RPM
PAM ENTRADA	71B14	
TORQUE SAÍDA	31.04	N.m
TORQUE NOMINAL	73.83	N.m
POTÊNCIA NOMINAL	0.88	KW
FATOR SERVIÇO	2.38	
EFICIÊNCIA DINÂMICA	0.82	

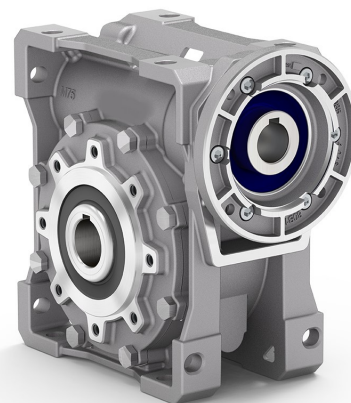

QUANTIDADE DE ÓLEO (L)

B3/H1	B6/H4	B7/H3	B8/H2	V5/H5	V6/H6
0.15	0.15	0.15	0.15	0.15	0.15

CARGAS RADIAIS E AXIAIS



n_2 [min-1]	FA [N]	FR [N]
200	240	1200
100	300	1500
50	380	1900
15	560	2800

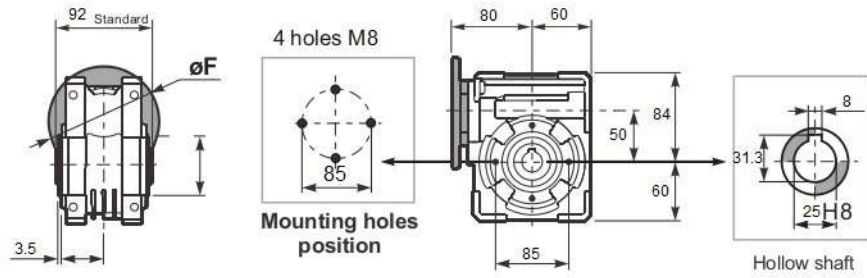

Square flange FA

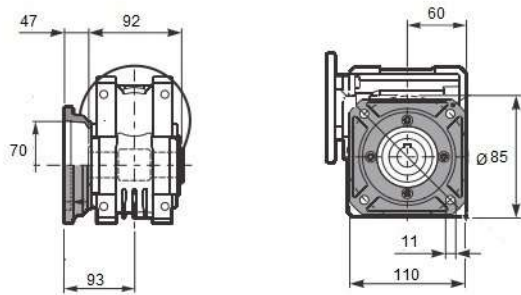

Square flange FB

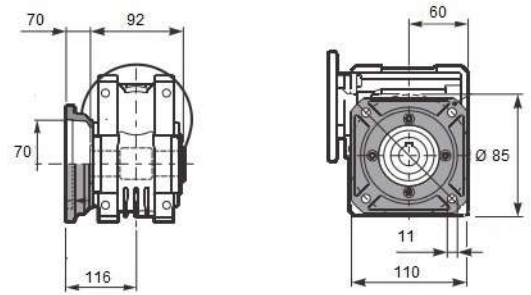

Feet

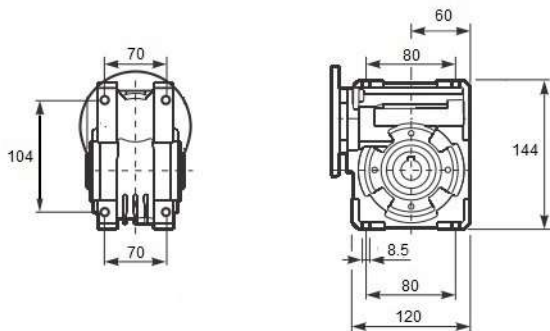

Reaction arm

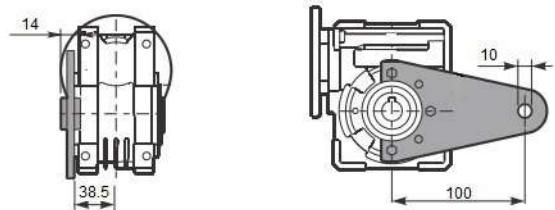

Single Shaft

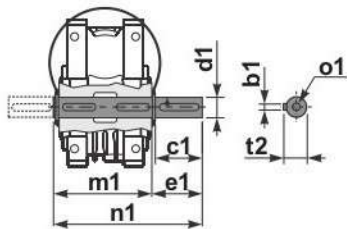

b1	c1	d1	e1	m1	n1	t2	$\phi 1$
8	50	25	53.5	92	153	28	M10

1400 rpm	N2	Relação	P1	FS	P1n	M2	Rend.	Fr max	Veio		Flanges de entrada		
	rpm	i	kW		kW	Nm	%	N	Entrada	Saída	63	71	80
UMSG50	187	7,5	1,1	1,5	1,6	71	0,88	1805	19	25		B14/B5	B14/B5
	140	10	1,1	1,1	1,2	70	0,86	1987			B14/B5	B14/B5	
	93	15	0,75	1,2	0,88	73	0,82	2274			B14/B5	B14/B5	
	70	20	0,75	0,9	0,68	72	0,79	2503			B14/B5	B14/B5	
	56	25	0,55	1,0	0,54	69	0,76	2696			B14/B5	B14/B5	
	47	30	0,55	1,0	0,57	83	0,72	2865			B14/B5	B14/B5	
	35	40	0,37	1,1	0,42	77	0,67	3153			B14/B5		
	28	50	0,37	0,9	0,34	73	0,63	3397			B14/B5	B14/B5	
	23	60	0,25	1,1	0,28	68	0,59	3610	14			B14/B5	B14/B5
	18	80	0,25	0,9	0,22	64	0,53	3973				B14/B5	B14/B5
	14	100	0,18	1,0	0,18	52	0,49	4280		11		B14/B5	