

MODELO	UMSG130	
Ø VEIO SAÍDA	45	mm
RÁCIO APROXIMADO	30	
RÁCIO EXATO	30.00	
VELOCIDADE SAÍDA	49	RPM
VELOCIDADE SAÍDA EXATA	49	RPM
POTÊNCIA ENTRADA	7.50	KW
ROTAÇÃO ENTRADA	1400	RPM
PAM ENTRADA	132B5	
TORQUE SAÍDA	1227.77	N.m
TORQUE NOMINAL	1047.69	N.m
POTÊNCIA NOMINAL	6.4	KW
FATOR SERVIÇO	0.85	
EFICIÊNCIA DINÂMICA	0.80	



QUANTIDADE DE ÓLEO (L)

B3/H1	B6/H4	B7/H3	B8/H2	V5/H5	V6/H6
4.5	3.5	3.5	3.3	4.5	3.3

CARGAS RADIAIS E AXIAIS



n_2 [min ⁻¹]	FA [N]	FR [N]
200	960	4800
100	1240	6200
50	1560	7800
15	2400	12000



Square flange FA

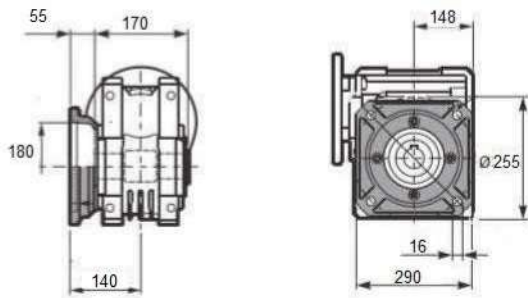

Single Shaft

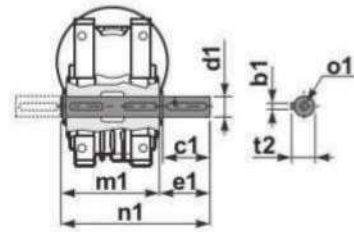

b1	c1	d1	e1	m1	n1	t2	o1
14	80	45	85	170	265	48.5	M16

Feet

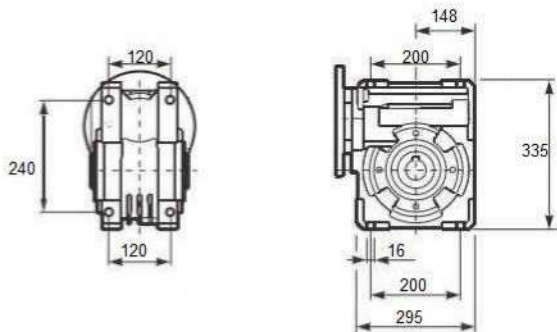

Reaction arm

